

**United States Court of Appeals
for the Federal Circuit**

GENERAL ELECTRIC COMPANY,
Appellant,

v.

INTERNATIONAL TRADE COMMISSION,
Appellee,

and

**MITSUBISHI HEAVY INDUSTRIES, LTD.,
AND MITSUBISHI POWER SYSTEMS AMERICAS,
INC.,**
Intervenors.

2010-1223

Appeal from the United States International Trade
Commission in Investigation No. 337-TA-641.

Decided: February 29, 2012

WILLIAM F. LEE, Wilmer Cutler Pickering Hale and Dorr
LLP, of Boston, Massachusetts, argued for appellant. With
him on the brief were RICHARD W. O'NEILL, LOUIS W.
TOMPROS and SARAH B. PETTY.

JAMES A. WORTH, Attorney, Office of General Counsel, United States International Trade Commission, of Washington, DC, argued for appellee. With him on the brief were JAMES M. LYONS, General Counsel, and WAYNE W. HERRINGTON, Assistant General Counsel.

DONALD R. DUNNER, Finnegan, Henderson, Farabow, Garrett & Dunner, LLP, of Washington, DC, argued for intervenors. With him on the brief were THOMAS H. JENKINS, THOMAS W. WINLAND, JEFFREY C. TOTTEN and TYLER M. AKAGI; and ROGER D. TAYLOR, of Atlanta, Georgia.

Before RADER, *Chief Judge*, NEWMAN, and LINN, *Circuit Judges*.

NEWMAN, *Circuit Judge*.

The General Electric Company appeals the decision of the United States International Trade Commission, holding that certain variable speed wind turbines imported by Mitsubishi Heavy Industries, Ltd. and Mitsubishi Power Systems Americas, Inc. (together “Mitsubishi”) do not violate section 337 of the Tariff Act, 19 U.S.C. §1337.¹ The patents at issue were General Electric’s United States Patents No. 7,321,221 (the ’221 patent), No. 5,083,039 (the ’039 patent), and No. 6,921,985 (the ’985 patent).

¹ *In the Matter of Certain Variable Speed Wind Turbines and Components Thereof*, Inv. No. 337-TA-641, USITC Pub. 4202 (Jan. 2010), 2010 WL 5176683, (*Final Determination*); *In the Matter of Certain Variable Speed Wind Turbines and Components Thereof*, Inv. No. 337-TA-641, USITC Pub. 4202 (Aug. 2009), 2010 WL 5176683, (*Initial Determination*).

THE COMMISSION PROCEEDINGS

On General Electric's complaint, the Commission conducted an investigation and the Administrative Law Judge held an evidentiary hearing on all of the issues raised by General Electric as complainant, by Mitsubishi as respondent, and by the Commission's investigators. By Final Initial Determination, including 126 pages of findings of fact and conclusions of law, the ALJ held that section 337 is violated by the imported Mitsubishi turbines. The ALJ determined that the '221 patent is not invalid by reason of obviousness; that the '039 patent is not invalid by reason of obviousness, written description, or enablement; and that the '985 patent is not invalid by reason of obviousness or best mode. The ALJ also determined that the three patents are infringed by the imported Mitsubishi wind turbines, and that the intent element of inequitable conduct as to the '985 patent was not established. The ALJ also determined that the domestic industry requirement is not met as to the '221 patent, but is met as to the '039 and '985 patents.

Each participant requested review by the full Commission of the ALJ's adverse rulings. The Commission "noticed" review of the Final Initial Determination except for (1) the issue of importation and (2) the intent finding of inequitable conduct.² The Commission received briefing and argument on all of the other issues, and held by Final Determination that the '039 patent is not invalid by reason of obviousness or written description, that the '039 and '221 patents are not infringed by the Mitsubishi turbines, and that the domestic industry requirement is not met as to any

² *In the Matter of Certain Variable Speed Wind Turbines and Components Thereof; Notice of Commission Determination to Review a Final Initial Determination of the Administrative Law Judge*, 74 Fed. Reg. 52,975 (Oct. 15, 2009).

of the patents. The Commission took no position on any other issue in the Final Initial Determination, and held that section 337 is not violated by the Mitsubishi imported turbines. This appeal followed.

The '039 patent expired on February 1, 2011, and this court dismissed that portion of the appeal as moot, vacating the Commission's rulings as to the '039 patent.³ We now affirm the Commission's ruling that the '221 patent is not infringed. We reverse the Commission's determination of no domestic industry as to the '985 patent, and remand for further proceedings with respect to the '985 patent.

VARIABLE SPEED WIND TURBINES

Electric power is generated from energy sources such as coal, natural gas, nuclear fission, flowing water, and wind, whereby the energy causes the rotation of magnets or electromagnets in association with coils of wire, producing an electric current. See the parties' joint tutorial of the technology presented to the ALJ, Hr'g Tr. Apr. 29, 2009.

The electric current generated by wind turbines is usually fed to a centralized power grid, where electricity from various facilities is combined, stored, and distributed. Although wind is an advantageous source of energy, wind activity tends to be extremely irregular, whereas uniform electric current of fixed frequency is required to be fed to the power grid. This led to the development of variable speed wind turbines, which convert the irregular product of wind energy into the fixed-frequency alternating current (AC) required by the power grid. The General Electric '221 and '985 patents are directed to structure and circuitry that protect the turbine components from the effects of irregu-

³ *General Elec. Co. v. Int'l Trade Comm'n*, No. 2010-1223 (Fed. Cir. Jan. 19, 2011) (unpublished order).

larities caused by emergency events such as lightning strikes, downed power lines, short circuits, and the like.

The products whose importation is charged with violation of section 337 are variable speed wind turbines designated as Mitsubishi models MWT 92 and MWT 95. As products of the domestic industry, General Electric designated its models SLE, XLE, and SE. The Mitsubishi and General Electric turbines have the structure and circuit configuration called a “doubly-fed induction generator,” illustrated as follows:

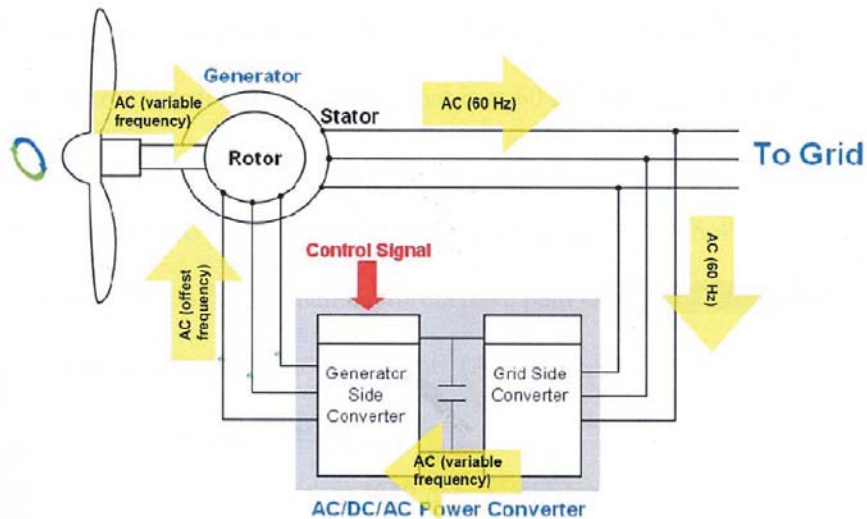

Gen. Elec. Br. 17 (from J.A. 2222). In operation, the wind turns the blades and causes the shaft to rotate, thereby spinning the rotor and producing a magnetic field in the winding coils, generating electric current. To produce AC electricity of uniform and fixed frequency, in doubly-fed induction generators a second magnetic field is imposed by current drawn from the grid and, by operations not here at issue, the system produces electricity of the desired uniform frequency. Testimony of Dr. Collins, Hr’g Tr. 46-48 (Apr. 29, 2009), J.A. 2746-48.

I

THE '221 PATENT

The '221 patent relates to protective circuitry for variations in grid supply voltage in doubly fed induction generator wind turbines. The patent explains that

the problem arises that large voltage differences between grid and stator coils occur on variations of the supply voltage amplitudes caused in the grid by, e.g., short circuits. These differences cause, in turn, a strong current rise in the stator coils directly coupled to the grid. These strong current rises in the stator coils are caused because the induction generator is usually fully excited at the variation of the grid frequency amplitude and mechanical energy is permanently supplied by the rotor. The strong current rise occurring in the stator coils on variations of the supply voltage leads to high induction voltages in the rotor windings, which can, in turn, cause damages on the converters used for feeding the rotor current.

'221 patent, col.1 ll.45-57. The '221 patent employs a protective circuit called a "crowbar circuit," which decouples the current feed-in unit from the rotor windings when large current variations occur, thereby protecting the circuitry. Both the imported Mitsubishi and the domestic General Electric wind turbines employ a system of protective decoupling of the rotor windings from the feed-in converter, but the turbines differ in the method by which operation is restored. In the General Electric turbines recoupling of the circuitry occurs when the emergency-induced elevation in current has declined to a predetermined value as measured

in the turbine, and in the Mitsubishi turbines recoupling occurs after a pre-set period of time.

A. Claim Construction

The issue of infringement of the '221 patent was determined based on the Commission's construction of the '221 claims with respect to the method of restoring operation after an emergency-induced decoupling. The claim construction question is the meaning of the term "predetermined value" in the '221 patent claim 5 (emphases added):

5. A wind turbine, comprising:
 - a rotor with at least one rotor blade, the rotor being rotatably arranged with regard to a substantially horizontal rotor axis;
 - an induction generator whose rotor windings are coupled to the rotor and whose stator coils can be coupled to a voltage grid;
 - a feed-in unit for feeding currents into the rotor windings;
 - a control unit for controlling the frequency of the fed-in currents depending on the rotor rotation frequency, and
 - an emergency unit which can be operated to electrically decouple the feed-in unit from the rotor windings in case of variations of the grid voltage amplitude, wherein the emergency unit comprises a release arrangement for releasing the rotor current feed-in after decoupling, when the currents generated in the rotor windings by variation of the grid voltage amplitude triggering the decoupling are declined to a predetermined value.

The Commission held that the claim's release arrangement "requires the wind turbine to measure current or an ade-

quate proxy for current to determine whether the current has declined to a level previously decided upon.” *Final Determination*, at 26. The Commission held that a pre-set period of time is not such a proxy for current.

General Electric argues that the term “predetermined value,” construed in light of the specification, includes not only a value of current, but also a predetermined period of time, for the ’221 patent states that turbine operation can be resumed “under consideration of a predetermined time constant.” ’221 patent, col.3 ll.5-6. General Electric points out that the ’221 patent recognizes and recites time periods for externally-caused fluctuations in current, and argues that the Commission incorrectly construed the claims as excluding a predetermined time constant from “predetermined value.” General Electric cites several supporting statements in the ’221 specification:

Basically, resuming the feeding of rotor current can be accomplished under consideration of a predetermined time constant. In view of an increase in plant safety, it has been shown particularly expedient that when the rotor current is sensed as a two or three-phase signal or the rectified current is sensed as a single-phase signal and the current that was sensed drops to a pre-determined value, the feeding of the rotor current is resumed. Current transformers (e.g. current-compensated transformers) can be used for sensing the currents.

. . . When the amplitude of the rotor current has dropped sufficiently after 100 to 200 msec [milliseconds], the feeding of the rotor current can be resumed on recurrence of the supply voltage within the framework of the method according to the invention.

. . . As is explained above, in this case the rotor and the starter current diminish within 50 to 150 msec depending on the resistance.

Id. at col.3 ll.4-13, col.3 ll.37-40, col.3 ll.54-56. General Electric, citing *Honeywell International, Inc. v. ITT Industries, Inc.*, 452 F.3d 1312, 1318 (Fed. Cir. 2006), argues that because the specification refers to a predetermined time constant “within the framework of the method according to the invention,” the passage of a fixed period of time is included in the scope of the claims. The ALJ agreed with General Electric’s position, and held that “[a] time constant, in the form of a specific time range, may be considered when determining that predetermined value.” *Initial Determination*, at 70.

The full Commission did not agree with the ALJ. The Commission found that the portion of the specification that mentions a “predetermined time constant” is in the context of an “increase in plant safety,” col.3 l.6, and that the specification teaches that measurement of current, not time, increases safety. The Commission found that the specification “presents the latter current-drop mode as an improvement on the former amount-of-time mode.” *Final Determination*, at 27. The ’221 specification’s only description of the operation of the invention shows recoupling upon measurement of a predetermined value of current, not upon passage of a pre-set period of time.

We share the Commission’s view that the patentee describes the invention as the resumption of current feed after the current is restored to the predetermined value, not after a fixed period of time. The specification describes and enables the deactivation of the crowbar circuit “[w]hen the current drops afterwards to a predetermined value” of current; there is no description or exemplification of re-

sumption of operation by recoupling the rotor currents after a pre-set period of time. The specification states:

As is shown in FIG. 3, short-circuit element 60 ('crow bar') can be realized as a B6 bridge. In this case, the dying out of the rectified rotor currents can be accomplished via a current transformer resistor 62 in the B6 bridge. When the intermediate circuit voltage in converter 50 exceeds a predetermined value due to exceedingly high rotor currents, the crow bar formed as a B6 bridge is fired. Then, the same procedure as in the case of a short-circuit of the grid is executed. Should an exceedingly high current appear in the rotor due to a short-term undervoltage of the grid, the turbine really acts like in the case of a short-circuit of the grid. *When the current drops afterwards to a predetermined value*, the thyristors of the B6 bridge become blocked and the short-circuiting of the rotor windings 34 is ended. The feed-in of rotor currents is then resumed. Consequently, *the thyristors form the release arrangement of the embodiment* of the present invention.

'221 patent, col.5 ll.8-24 (emphases added). Figure 3, to which this passage refers, shows the crowbar circuit 60 formed as a bridge that short-circuits and thereby decouples the rotor windings 34 upon the occurrence of exceedingly high rotor current. Figure 3, a detailed view of the circuit diagram in patent Figure 1, shows the transformer resistor 62, the rotor-sided rotor converter 54, and stator coils 32:

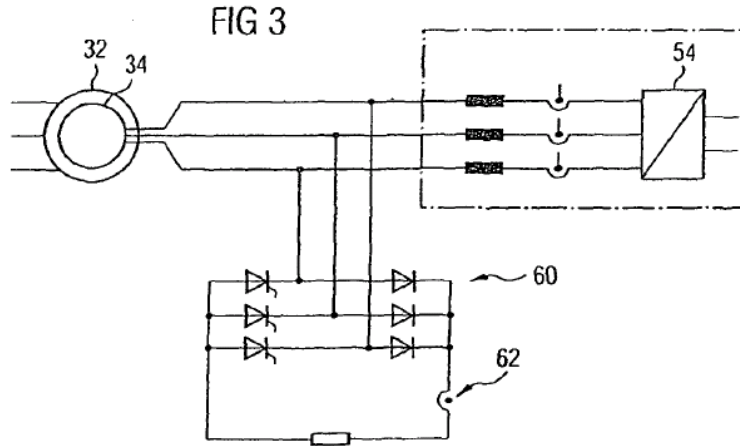

The specification explains that the crowbar circuit 60 is deactivated, the bridge is blocked, and the rotor windings are recoupled, when the current drops to the predetermined value.

No embodiment in the patent, no drawing, no circuitry, shows recoupling solely after a predetermined period of time. Although the specification shows that General Electric knew that various electrical disturbances for which this protective circuitry is intended occur within a known duration, the '221 invention as claimed is explicitly limited to recoupling when the actual end of the specific disturbance has been determined by measurement of when the current has declined to a predetermined value. Although General Electric recognized and described the usual duration of such electrical disturbances, a possibly broader disclosure accompanied by an explicit narrow claim shows the inventor's selection of the narrow claim scope. *See* 35 U.S.C. §112 ¶2 ("The specification shall conclude with one or more claims particularly pointing out and distinctly claiming the subject matter which the applicant regards as his invention.").

The Commission held that the '221 claims are directed to a predetermined value of current or a proxy for current. The inclusion of a proxy for current comports with *Linear Technology Corp. v. International Trade Commission*, 566 F.3d 1049, 1060 (Fed. Cir. 2009), which held that “monitoring the current to the load” could be indirectly measured by voltage, for “once voltage is known, one skilled in the art would recognize that Ohm’s Law⁴ easily allows current to be calculated, therefore monitoring current indirectly by monitoring voltage.” The Commission’s construction of “predetermined value” as a value of current or a proxy for current “stays true to the claim language and most naturally aligns with the patent’s description of the invention.” *Phillips v. AWH Corp.*, 415 F.3d 1303, 1316 (Fed. Cir. 2005) (en banc) (quoting *Renishaw PLC v. Marposs Società per Azioni*, 158 F.3d 1243, 1250 (Fed. Cir. 1998)). This claim construction is affirmed.

B. Infringement

For infringement, every element and limitation of a claim of the patent must be found in the accused device, literally or in accordance with the doctrine of equivalents. It is not disputed that the Mitsubishi turbines do not measure current or voltage in determining when to resume the feed-in connection after decoupling has occurred. The record contains expert testimony on the question of whether a pre-set time period in the Mitsubishi turbines is an adequate proxy for current. The experts for both sides agreed

⁴ “Ohm’s Law is a principle of electrical circuits and is represented by the equation I (current) = V (voltage) / R (resistance). Thus, it states that the current through a conductor between two points is directly proportional to the voltage across the two points, and inversely proportional to the resistance between them.” *Linear Tech.*, 566 F.3d at 1059 n.4.

that there is no predictable relationship between the duration of low-voltage events and the restoration of safe current levels, because of the variety of factors that can affect such events and their duration. Testimony of Dr. Toliyat, Hr'g Tr. 1453:10-19 (May 15, 2009), J.A. 4168; Testimony of Dr. Collins, Hr'g Tr. 978:12-22 (May 13, 2009), J.A. 3645. The experts' testimony supports the Commission's finding that a predetermined value of time "cannot serve as an adequate proxy for current because the relationship between the two cannot be guaranteed." *Final Determination*, at 27. We affirm the Commission's finding that the Mitsubishi turbine, whereby recoupling occurs after a pre-set period of time, does not literally infringe the '221 claims.

General Electric argued that even if there is not literal infringement, the doctrine of equivalents applies because the system in the '221 patent and the Mitsubishi system perform substantially the same function in substantially the same way to achieve the same result, whether recoupling is measured by current drop or by the passage of time. *See Voda v. Cordis Corp.*, 536 F.3d 1311, 1326 (Fed. Cir. 2008) (summarizing the criteria of infringement based on equivalency). The Commission found that a system that measures when the specific emergency event has actually ended is not substantially the same as a system that applies the same time period to all emergency events. This finding was supported by substantial evidence in the form of the experts' testimony with respect to the technological facts. The Commission's determination that the Mitsubishi turbines do not infringe the '221 patent under the doctrine of equivalents is affirmed.

C. Domestic Industry

In view of our affirmance of noninfringement of the '221 patent, we affirm that section 337 is not violated based on

the '221 patent. Although the Commission also ruled that General Electric's turbines do not now practice the '221 invention and therefore do not meet the domestic industry requirement as to this patent, we do not reach that aspect, and vacate the Commission's ruling thereon.

II

THE '985 PATENT

The '985 patent is directed to wind turbine circuitry that provides a stable output of electricity to the grid during low voltage events. The Commission construed the '985 patent claim 15, the only claim at issue, in a manner that excluded the General Electric turbines from the scope of the claim, and on this claim construction the Commission held that there is no domestic industry as to the '985 patent. The domestic industry requirement of the Tariff Act is set forth in 19 U.S.C. §1337(a), subsections (2) and (3):

§1337(a)(2) Subparagraphs (B), (C), (D), and (E) of paragraph (1) [concerning violations of section 337] apply only if an industry in the United States, relating to the articles protected by the patent, copyright, trademark, mask work, or design concerned, exists or is in the process of being established.

(a)(3) For purposes of paragraph (2), an industry in the United States shall be considered to exist if there is in the United States, with respect to the articles protected by the patent, copyright, trademark, mask work or design concerned—

(A) significant investment in plant and equipment;

(B) significant employment of labor or capital;
or

(C) substantial investment in its exploitation,
including engineering, research and develop-
ment, or licensing.

The '985 patent, entitled "Low Voltage Ride Through for Wind Turbine Generators," is directed to wind turbine structure and circuitry that provide "ride through" stabilization in periods of voltage fluctuation. The '985 specification describes low voltage ride through as providing one or more of the following responses to voltage fluctuation:

1) to remain synchronized to the power grid during severe voltage fluctuations, 2) to maintain functioning of the blade pitch system in spite of lack of voltage at the generator terminals, 3) to protect the power converter and generator from high voltages and currents during the voltage fluctuation, and 4) to temporarily shut down non-vital sub-systems that could be damaged by exposure to low voltages or could be tripped by either circuit breaker action or fuse operation.

'985 patent, col.2 ll.26-34. Ride through in the '985 patent is achieved by circuitry that monitors voltage and provides supplemental power from an uninterruptible power supply when the system signals the need for ride through, and thereby protects the power converter and generator during voltage fluctuations while preserving the turbine's connection with the power grid.

The Commission construed the '985 patent claim 15 with attention to the aspect that is disputed in application

to the General Electric turbines (emphasis added to the aspect of concern):

15. A wind turbine generator comprising:
 - a generator;
 - a power converter coupled with the generator, the power converter having an inverter coupled to receive power from the generator, a converter controller coupled with the inverter to monitor a current flow in the inverter wherein the converter controller is coupled to receive power from an uninterruptible power supply during a low voltage event, and a circuit coupled with the input of the inverter and with the converter controller *to shunt current from the inverter and generator rotor* in response to a control signal from the converter controller.

Patent Figure 4 is “a block diagram of one embodiment of a power converter having functionality to respond to a low voltage event.” *Id.* at col.4 ll.44-46:⁵

⁵ This drawing as shown in the briefs is from the patent application, for it was agreed that Figure 4 as printed in the '985 patent inadvertently omitted the line connecting Crowbar Circuit 440 to the Rotor Side of the Inverters.

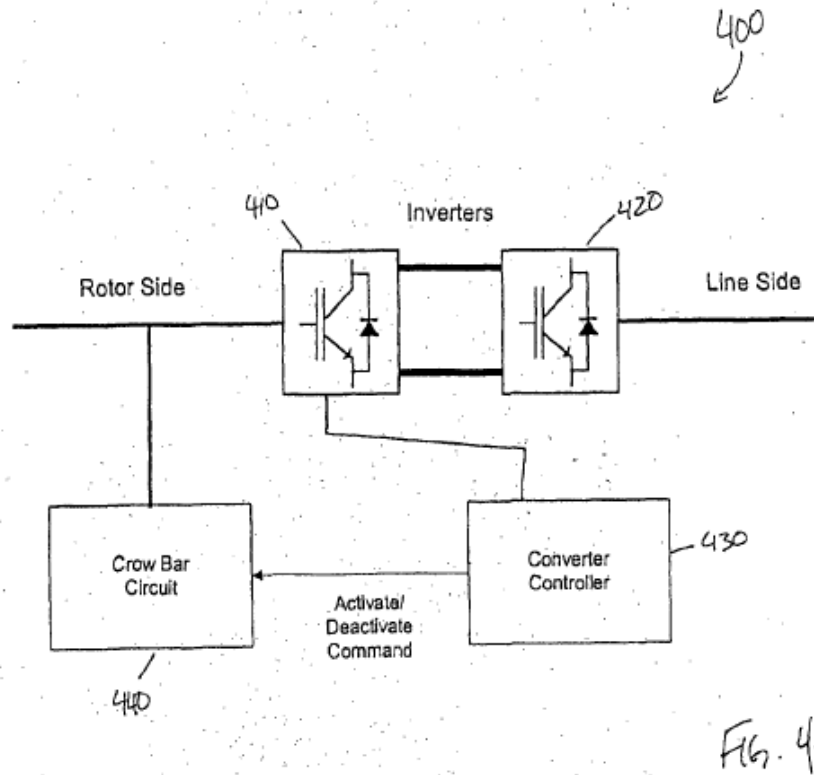

Figure 4 shows back-to-back inverters as part of the power converter; the inverters receive power as needed during a low voltage event “to keep the wind turbine generator connected to and synchronized with the power grid.” ’985 patent, col.6 ll.27-29. The specification describes the connections and functions of the components, including the following:

Inverter 410 is coupled with the generator (not illustrated in FIG. 4) and to inverter 420 which is coupled with the power grid. Crowbar circuit 440 is coupled with the output of the generator rotor. Converter controller 430 is coupled to receive data

indicating the current flowing in inverter 410 and to control crowbar circuit 440. In one embodiment, converter controller 430 selectively activates and deactivates crowbar circuit 440 to maintain the current in inverter 410 within an acceptable range.

Crowbar circuits are known in the art and any appropriate (e.g., a circuit having sufficient power ratings) crowbar circuit can be used. In general, crowbar circuit 440 operates to shunt current from the generator rotor and inverter 410 and maintain inverter currents within safe levels. Thus, during normal operation crowbar circuit 440 is inactive. During a low voltage event converter controller 430 selectively activates crowbar circuit 440 to maintain current levels in a safe range. Thus, crowbar circuit 440 and converter controller 430 are part of a system that allows a wind turbine generator to ride through low voltage events and remain synchronized to the power grid.

Id. at col.4 l.50 to col.5 l.3.

The issue of claim construction was whether claim 15 requires that the circuit that shunts current on signal from the converter controller is located entirely outside of the inverter. The Commission held that the shunt circuit must be separate from the inverter, for otherwise the circuit could not shunt current *from* the inverter, as claim 15 states. On this construction, the Commission ruled that “[General Electric’s] shunt circuit does not shunt current from the inverter because it is within the inverter.” *Final Determination*, at 41-42. The ALJ had reached a different conclusion, holding that “whether a particular shunting circuit located within the inverter (as opposed to outside it) meets the claim limitation will depend upon whether it is found to be ‘coupled with the input of the inverter and the converter

controller,' as required by the claim." *Initial Determination*, at 98. The ALJ held that the claim does not contain the additional requirement that the shunt circuit is located entirely outside of the inverter.

The specification, in describing how the circuit shunts current from the generator rotor and the inverter, and describing the connections of the components, does not require that the components are entirely separate. Providing "a protective circuit that maintains currents within an allowable range," col.4 ll.35-36, does not require that the inverter and shunt circuits are entirely separate. Nor do the words of claim 15 "coupled with the input of the inverter and with the converter controller," connote physical separation of the shunt circuit from the inverter.

The Commission apparently viewed the claim clause "shunt current from the inverter and generator rotor" in isolation from its context as "a circuit coupled with the input of the inverter and with the converter controller." However, the function of the shunt circuit does not depend on whether the shunt circuit is entirely outside of the inverter, and the '985 specification does not require separation of the inverter and the shunt circuit in order for that circuit to be coupled with the input of the inverter and with the converter controller; rather, the term "coupled with" indicates a connection. *See Johnson Worldwide Assocs., Inc. v. Zebco Corp.*, 175 F.3d 985, 992 (Fed. Cir. 1999) ("'[C]oupled' generically describes a connection, and does not require a mechanical or physical coupling.").

A similar argument was rejected in *NTP, Inc. v. Research in Motion, Ltd.*, 418 F.3d 1282 (Fed. Cir. 2005), where some of the claims recited a receiver "connected to" or "coupled to" a processor or that the receiver "transfers" information to the processor. The accused infringer in *NTP*

had argued that “connected to,” “coupled to,” and “transfer from” each requires the receiver and the processor to be separate, but the court concluded that “the two components could be connected, joined, or linked together by wires or other electrical conductors and still be located in the same housing or even on the same circuit board.” 418 F.3d at 1310-11. The court also held that the function that information is transferred between two entities does not require physical separation of the entities. *Id.* at 1310. *NTP* does not support the Commission’s ruling that the word “from” requires physical separation of the shunt circuit and the inverter.

We conclude that claim 15 requires that the circuit is coupled with the input of the inverter and the converter controller, whereby the current is shunted from the inverter and the rotor; this requirement does not limit the placement of the shunting circuitry to a location entirely external to the inverter. As in *Linear Technology*, “there is nothing in the claim language or specification that supports narrowly construing the terms to require a specific structural requirement or entirely distinct [circuits]. Rather, the [circuits] must only perform their stated functions.” 566 F.3d at 1055.⁶

Mitsubishi also argues that the General Electric turbines embody a modification of the circuitry system in the ’985 patent, and that this modification is separately pat-

⁶ Mitsubishi submitted a letter in accordance with Fed. R. App. P. 28(j), arguing that General Electric stated a position before the PTO during the ongoing reexamination of the ’985 patent that contradicts its arguments here. General Electric responds that its argument distinguishing a certain reference does not conflict with its position here. On the information before us, the reexamination arguments do not affect our conclusion.

ented in General Electric's U.S. Patent No. 7,239,036. Mitsubishi states that if General Electric's turbines practice the subject matter claimed in a separate patent, they cannot practice the invention of the '985 patent. That is not correct, for a separately patented invention may indeed be within the scope of the claims of a dominating patent. See *Hoechst Celanese Corp. v. BP Chems. Ltd.*, 78 F.3d 1575, 1582 (Fed. Cir. 1996) ("The fact of separate patentability presents no legal or evidentiary presumption of noninfringement"); *Atlas Powder Co. v. E.I. du Pont De Nemours & Co.*, 750 F.2d 1569, 1580 (Fed. Cir. 1984) (an improvement in a step of a patented method, even if separately patentable, may not avoid infringement). The scope of the '985 patent is determined on its own terms, independent of whether other aspects or modifications of the technology are separately patented. The domestic industry requirement is not negated if the technology as employed in the domestic industry has been modified from its form when the patent was obtained.

We conclude that claim 15, correctly construed, covers the domestic industry turbines. The Commission erred in determining that General Electric does not meet the domestic industry requirement with respect to the '985 patent. That ruling is reversed. See *Osram GmbH v. Int'l Trade Comm'n*, 505 F.3d 1351, 1359 (Fed. Cir. 2007) (reversing finding of no domestic industry, on corrected claim construction).

III

OTHER '985 PATENT ISSUES

The Initial Determination held that the Mitsubishi turbines infringe the '985 patent, that the patent is valid, and that inequitable conduct had not been shown. The *Notice of*

Commission Determination to Review a Final Initial Determination stated that the Final Initial Determination would be reviewed except for the issues of importation and the “intent” element of the inequitable conduct ruling. See n.2 *supra*. However, for the ’985 patent the Commission decided only the domestic industry question, and took no position on any other issue. The Commission states on this appeal that the other issues decided by Final Initial Determination are not subject to judicial review because they are not a Commission determination. Commission’s Br. at 49 (the “initial determination has no effect as a Commission determination in this case”). This removal from finality is in stark tension with the statutory purpose of expedition in Commission proceedings, for the Commission now holds that issues of the Initial Determination that are “noticed” but not reviewed are not subject to the statutory right of appeal:

19 U.S.C. §1337(c) *Determinations; review*.

. . . Each determination under subsection (d) or (e) [exclusion from entry] of this section shall be made on the record after notice and opportunity for a hearing in conformity with the provisions of subchapter II of chapter 5 of Title 5. All legal and equitable defenses may be presented in all cases. . . Any person adversely affected by a final determination of the Commission under subsection (d), (e), (f), or (g) of this section may appeal such determination, within 60 days after the determination becomes final, to the United States Court of Appeals for the Federal Circuit for review in accordance with chapter 7 of Title 5. . . .

The regulations provide that the initial determination becomes the Commission’s determination unless the Com-

mission orders review of the initial determination or certain issues therein:

19 C.F.R. §210.42 *Initial determinations.*

...

(h)(2) An initial determination under §210.42(a)(1)(i) [issues of violation of section 337] shall become the determination of the Commission 60 days after the date of service of the initial determination, unless the Commission within 60 days after the date of such service shall have ordered review of the initial determination or certain issues therein or by order has changed the effective date of the initial determination.

Thus issues not selected for review by the full Commission may be appealed to the Federal Circuit in accordance with 19 U.S.C. §1337(c). However, the Commission states that issues selected but not reviewed may not be appealed to the Federal Circuit. The Commission states that this anomalous procedure was established by this court in *Beloit Corp. v. Valmet Oy*, 742 F.2d 1421 (Fed. Cir. 1984), and was confirmed by regulatory amendment (with emphasis added to the 2008 amendment at issue):

19 C.F.R. §210.45 *Review of initial determinations on matters other than temporary relief.*

...

(c) *Determination on review.* On review, the Commission may affirm, reverse, modify, set aside or remand for further proceedings, in whole or in part, the initial determination of the administrative law judge. *In addition, the Commission may take no po-*

sition on specific issues or portions of the initial determination of the administrative law judge. The Commission also may make any findings or conclusions that in its judgment are proper based on the record in the proceeding. If the Commission's determination on review terminates the investigation in its entirety, a notice will be published in the Federal Register.

Thus the Commission holds that when the full Commission does not review an issue that it noticed for review, that issue is removed from access to judicial review. This interpretation conflicts with the statutory right of judicial review of Commission determinations, provided in 19 U.S.C. §1337(c). Such interpretation also conflicts with the principles of 19 C.F.R. §210.42(h) and §210.45(c), for no statutory or regulatory provision contemplates excluding a fully litigated ITC decision from access to judicial review.

The Commission has stated that the 2008 amendments are simply “procedural rules” promulgated “in order to increase the efficiency of its section 337 investigations.” *Rules of General Application and Adjudication and Enforcement*, 73 Fed. Reg. 38,316, 38,318 (July 7, 2008). The public comments on the 2008 amendments were directed to the proposed extensions of the time limits, and did not perceive the possibility of removal of fully litigated issues from finality. This consequence is not stated in the regulation, and is not explored in the comment record, where most commentators stated their concern for the lengthening of the target dates for Commission proceedings. For example:

[O]ne of the great advantages of Section 337 proceedings is their speedy adjudication. The role that the Commission and Section 337 have achieved as one of the key forums for protection of valuable U.S.

intellectual property rights rests on the speed and high quality of its adjudicatory process.

ITC Trial Lawyers Association, Comment to Notice of Proposed Rulemaking, ITC Doc. No. 296282, at 6 (Mar. 31, 2008). Speedy adjudication requires finality.

The amendment to §210.45(c) does not state that any issue on which the Commission takes no position is removed from access to the judicial review of Commission proceedings as provided by §210.42(h). Such a purpose would surely have occasioned comment; for example, the Intellectual Property Owners Association commented on the authorized extension of target dates, stating that:

IPO members place much value in the Commission's prompt and effective resolution of Section 337 investigations "at the earliest practicable time." (quoting 19 U.S.C. §1337(b)).

Comment to Notice of Proposed Rulemaking, ITC Doc. No. 296810, at 2 (Mar. 31, 2008). "Prompt and effective resolution" is not served by removing finality from the decision of issues on which Commission proceedings are over, thereby barring judicial appeal of those decisions.

The Commission states that this court held in *Beloit Corp. supra*, that any "noticed" issue of the Initial Determination on which the Commission took no position cannot be appealed to the court. That is inaccurate, for *Beloit* dealt with the situation in which the prevailing party in the Commission sought judicial review of other issues that the Commission did not reach. This court held that the prevailing party had no right of appeal, and that issues which had not been reviewed by the Commission were not appealable by the party that prevailed in the Commission.

Of course a prevailing party cannot appeal, for there is no controversy. *Am. Tel. & Tel. Co. v. Int'l Trade Comm'n*, 626 F.2d 841, 842 (CCPA 1980) (“Since the ITC determined that there was no §1337 violation by Bell, Bell is without standing to appeal.”). The court in *Beloit* did not authorize the Commission to deprive the losing party of its right of judicial appeal. 19 C.F.R. §210.42(h)(2) provides that issues decided by Initial Determination and not reviewed by the full Commission become final, and are appealable to the Federal Circuit. This right cannot be negated by taking no position on the issue. The result propounded by the Commission is anomalous: if the issue decided by initial determination is “noticed” and then reviewed by the Commission, the decision of that issue is routinely subject to appeal by the losing party; if the issue is not “noticed” by the Commission, the decision is again routinely subject to appeal by the losing party; but if the issue is “noticed” by the Commission and then not reviewed, the decision is not subject to appeal by the losing party. The consequences of this practice are illustrated in this case, for all contested issues concerning the '985 patent were investigated by the Commission, tried to the ALJ, decided by Initial Determination, yet nearly all were held unavailable for judicial review. Thus we are obliged to remand to the Commission for undefined further proceedings, for which one may be confident only of further time and cost in the Commission and upon re-appeal to this court. The legislative purpose of expedited ITC resolution of unfair competition issues requires attention, in accord with statute and regulation, that issues decided by initial determination and not substantively reviewed by the full Commission are deemed determinations of the Commission in accordance with 19 C.F.R. §210.42(h)(2), and entitled to appeal in accordance with 19 U.S.C. §1337(c).

SUMMARY

The ruling that Mitsubishi's turbines do not violate section 337 because they do not infringe the '221 patent is affirmed. The ruling that the domestic industry requirement is not met as to the '221 patent is vacated as moot. The ruling that there is no domestic industry corresponding to the '985 patent is reversed, and the case is remanded for further proceedings with respect to the '985 patent.

**AFFIRMED IN PART, VACATED IN PART,
REVERSED IN PART, and REMANDED**